



# **Mailbox POLICY**

Approved December 14, 2020

# Mailbox Policy for the Town of Paris Municipality

For convenience and practicality, mailbox installations have been allowed within the right-of-way of Maine's public highways; however, it is important to recognize that such installations have two very important conditions:

- 1) The mailbox must be installed in accordance with applicable standards to ensure that mail can be delivered and that the mailbox does not create an obstacle or safety hazard to those that use or maintain the highway, and
- 2) The mailbox is installed entirely at the owner's risk. In other words, if the mailbox incurs damage during any sort of highway operations or maintenance, the property owner is not entitled to replacement or compensation. In fact, if the mailbox was not installed in accordance with the applicable standards as stated above, the owner may even be held liable for injuries or damages that may have been incurred as a result.

Mailbox design and installation standards are available from several sources, and mailbox owners are expected to consult this information prior to undertaking any mailbox installation or replacement. The following standards have nationwide relevance and were developed in cooperation with one another:

- The United States Postal Service (USPS) Mailbox Guidelines. The USPS defines the standards for mailbox construction, as well as the placement tolerance that must be met to accommodate postal operations. Specifics may be obtained from your local post office or online at: <https://www.usps.com/manage/mailboxes.htm>
- American Association of State Highway and Transportation Officials (AASHTO) Roadside Design Guide. The AASHTO Roadside Design Guide, Chapter 11: *Erecting Mailboxes on Streets and Highways* deals with the safety and construction of privately owned mailboxes, mailbox supports, and mailbox turnout designs and is less focused on postal operations. This publication may be obtained online through the AASHTO Bookstore at: [https://bookstore.transportation.org/Item\\_details.aspx?id=1807](https://bookstore.transportation.org/Item_details.aspx?id=1807)

In addition, if the mailbox is to be installed in an area with sidewalks, it is important to recognize that the sidewalks must continue to comply with ADA requirements:

- American Disabilities Act (ADA). The most current version of the ADA Standards for Accessible Design set forth the minimum requirements to ensure facilities are readily accessible to and usable by individuals with disabilities. <http://www.ada.gov/regs2010/2010ADAStandards/2010ADAstandards.htm#c4>

The municipality has developed this policy to promote compliance with these national standards and to help further clarify the expectations and responsibilities of Maine mailbox owners. Such compliance helps us ensure that we continue to provide safe, efficient and accessible highways for all. The following pages further specify the details associated with mailbox height, location, offset, and post type to minimize the potential hazards and conflicts associated with mailbox installations and to reduce the opportunities for damage to mailboxes.

## *Mailbox Installation Standards*

### **General Location:**

Whenever possible, your mailbox should be located after your driveway opening. This location placement improves visibility, minimizes the amount of snow that comes off of the snow plow, and improves the approach for your mail carrier. The diagram below further clarifies this preferred placement:

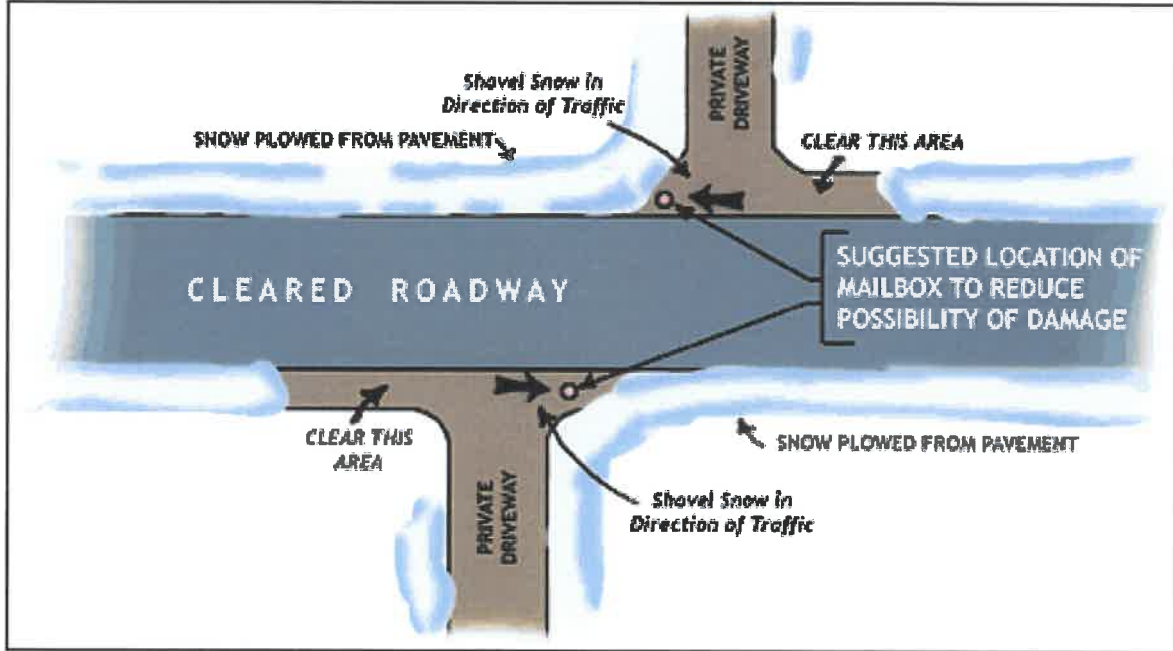

### **Mailbox Support Design:**

In many cases, it is best to use an extended arm type of post with a free-swinging suspended mailbox. This allows snowplows to sweep near or under boxes without damage to supports and provides easy access to the boxes by carrier and customers. The following picture shows a free-swinging suspended mailbox:



In addition, note the strategic placement of the red reflector on the point closest to the road. This will help your local snowfighter see and avoid your mailbox during winter storms.

**Offset:**

Mailboxes should be set back from the edge of the shoulder – regardless of whether the shoulder is gravel or paved. In other words, the face of the mailbox should be at least **one foot (1')** back from the edge of the normally plowed surface of the highway or the face of curb. Greater offset distances are encouraged whenever possible to allow the mail carrier to get further out of traffic and to further minimize potential damage to your mailbox. The following picture shows a mailbox with a reasonable offset:



Mailboxes in sidewalk areas should leave at least 36" behind the back of the box or the post, whichever is located the furthest from the road.



**Height:**

According to USPS standards, a mailbox must be installed with the bottom of the mailbox located between 41” and 45” high above the surface of the highway shoulder. We recommend that this height be closer to the 45” measurement to minimize conflict with the height of the plow truck wing when snow is being pushed back during, or between, winter storms. The following picture further clarifies the height considerations:



**Post Size, Type and Embedment:**

Mailbox posts must be sturdy enough to hold up the mailbox in all types of weather conditions, however they cannot be so rugged that they present a hazard to vehicles that inadvertently leave the road. If a mailbox support is struck by a vehicle, it must easily break away. Therefore, the following types of posts are deemed acceptable:

- **4” x 4” wooden posts** embedded **2 feet** into the ground. Larger wooden posts (4” x 6” or 6” x 6”) may be used only if the post is drilled through with an appropriate spade bit to create a shear plane. The following diagram indicates the necessary holes and spacing.

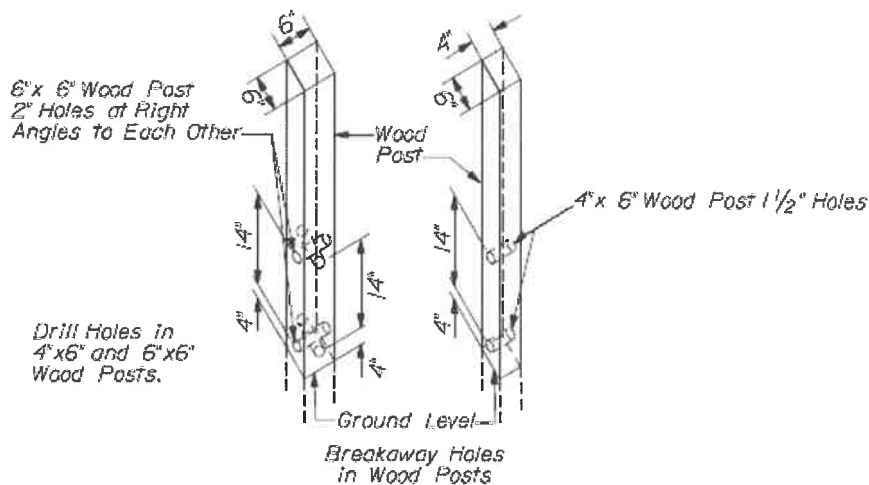

- **1” to 2” round diameter steel or aluminum pipe or standard U-channel post** embedded **2 feet** into the ground.

## §1401-A. Installations restricted

**1. Installing of buildings or fixtures.** Except as provided in subsection 1-A, a person may not install, erect or construct, or cause to be installed, erected or constructed, installations such as buildings, gasoline pumps or other fixtures in, upon or near any state or state aid highway, located as follows:

A. Within the full width of the right-of-way of any state or state aid highway as laid out by the State, the county or the town; [PL 2003, c. 452, Pt. L, §3 (NEW); PL 2003, c. 452, Pt. X, §2 (AFF).]

B. Within 33 feet of the center line of any state or state aid highway. This paragraph does not apply to installations or other property in existence on August 6, 1949. The commissioner has discretion to waive the application of this paragraph to the reconstruction of a building in the general location of the previously existing building if the commissioner determines that highway safety and the public welfare will not be adversely affected; or [PL 2003, c. 452, Pt. L, §3 (NEW); PL 2003, c. 452, Pt. X, §2 (AFF).]

C. Within 20 feet from the outside edge of any of the paved portion of any state or state aid highway having more than 2 travel lanes and having a total paved portion in excess of 24 feet in width. This paragraph does not apply to installations or other property in existence on September 1, 1955. [PL 2003, c. 452, Pt. L, §3 (NEW); PL 2003, c. 452, Pt. X, §2 (AFF).]  
[PL 2007, c. 191, §1 (AMD).]

**1-A. Limited waiver.** The commissioner may grant a person a written waiver of any of the provisions of subsection 1 and permit the construction of a fixture in, upon or near a state or state aid highway located in a municipality if:

A. The commissioner receives a written statement from the municipal officers requesting or supporting the waiver; [PL 2007, c. 191, §1 (NEW).]

B. The posted speed limit where the construction will occur is no more than 35 miles per hour; and [PL 2007, c. 191, §1 (NEW).]

C. The commissioner determines that highway safety and public welfare will not be adversely affected. [PL 2007, c. 191, §1 (NEW).]

The commissioner may include in the waiver any conditions the commissioner determines necessary to ensure public safety and welfare. Violation of the terms of a waiver constitutes a violation of this section.

[PL 2007, c. 191, §1 (NEW).]

**2. Penalties.** The following penalties apply to violations of this section.

A. A person who violates this section commits a civil violation for which a fine of not less than \$5 and not more than \$500 may be adjudged. [PL 2003, c. 452, Pt. L, §3 (NEW); PL 2003, c. 452, Pt. X, §2 (AFF).]

B. After having been adjudicated as having violated paragraph A, a person who unlawfully maintains any installations such as buildings, gasoline pumps or other fixtures for 30 days after the adjudication is subject to an additional fine of not more than \$50 for each day such installations are maintained. [PL 2003, c. 452, Pt. L, §3 (NEW); PL 2003, c. 452, Pt. X, §2 (AFF).]  
[PL 2003, c. 452, Pt. L, §3 (NEW); PL 2003, c. 452, Pt. X, §2 (AFF).]

**3. Application.** This section does not apply to the installations or other property devoted to the public use of any public utility or district and underground pipelines.  
[PL 2003, c. 452, Pt. L, §3 (NEW); PL 2003, c. 452, Pt. X, §2 (AFF).]

## SECTION HISTORY

PL 2003, c. 452, §L3 (NEW). PL 2003, c. 452, §X2 (AFF). PL 2007, c. 191, §1 (AMD).

The State of Maine claims a copyright in its codified statutes. If you intend to republish this material, we require that you include the following disclaimer in your publication:

*All copyrights and other rights to statutory text are reserved by the State of Maine. The text included in this publication reflects changes made through the Second Regular Session of the 129th Maine Legislature and is current through October 1, 2020. The text is subject to change without notice. It is a version that has not been officially certified by the Secretary of State. Refer to the Maine Revised Statutes Annotated and supplements for certified text.*

The Office of the Revisor of Statutes also requests that you send us one copy of any statutory publication you may produce. Our goal is not to restrict publishing activity, but to keep track of who is publishing what, to identify any needless duplication and to preserve the State's copyright rights.

PLEASE NOTE: The Revisor's Office cannot perform research for or provide legal advice or interpretation of Maine law to the public. If you need legal assistance, please contact a qualified attorney.

**§1402. Removal of obstructions**

When logs, lumber or other obstructions, without necessity, are left within the limits of any highway right-of-way under the supervision and maintenance of or construction by the department, it may cause them to be removed, and shall not be liable for loss or damage thereof, unless occasioned by design or gross negligence. When no one appears to pay for the expense and trouble of removal, the department may sell at public auction so much thereof as is sufficient for that purpose, including charges of sale. The person through whose neglect or willful default they were left may be prosecuted as for a nuisance. [PL 1971, c. 593, §22 (AMD).]

**SECTION HISTORY**

PL 1971, c. 593, §22 (AMD).

The State of Maine claims a copyright in its codified statutes. If you intend to republish this material, we require that you include the following disclaimer in your publication:

*All copyrights and other rights to statutory text are reserved by the State of Maine. The text included in this publication reflects changes made through the Second Regular Session of the 129th Maine Legislature and is current through October 1, 2020. The text is subject to change without notice. It is a version that has not been officially certified by the Secretary of State. Refer to the Maine Revised Statutes Annotated and supplements for certified text.*

The Office of the Revisor of Statutes also requests that you send us one copy of any statutory publication you may produce. Our goal is not to restrict publishing activity, but to keep track of who is publishing what, to identify any needless duplication and to preserve the State's copyright rights.

PLEASE NOTE: The Revisor's Office cannot perform research for or provide legal advice or interpretation of Maine law to the public. If you need legal assistance, please contact a qualified attorney.



- Unacceptable mailbox supports include: anything that is filled with concrete, masonry and stone structures, heavy steel structures, and most objects that were intended for other uses (e.g. antique plows, I-beams, and various other household tools and objects).

**NOTICE: Mailboxes, attachments or support systems not consistent with this policy are considered “Deadly Fixed Objects” (aka. “DFOs”) and are in violation of 23 MRSA §1401-A on state and state aid roads. On local roads, they can be considered as “obstructions” and a number of statutes relate to these obstructions. As such, when these installations are recognized by the municipality, the owner will be informed of the hazard and immediate removal will be requested. If the property owner does not comply with this request, the municipality may elect to remove the installation and seek reimbursement from the property owner for all costs incurred.**

This policy supersedes all previous similar policies and practices.

Approved by the Town of Paris Municipal Officers on December 14, 2020.

  
\_\_\_\_\_  
Russell Brackett, Chair

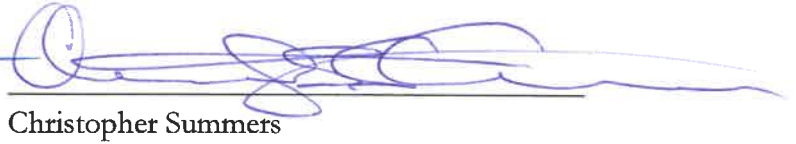
  
\_\_\_\_\_  
Christopher Summers

  
\_\_\_\_\_  
Peter Kilgore

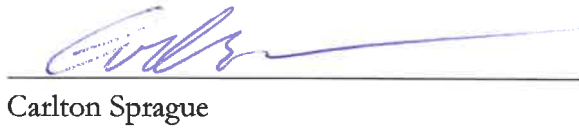
  
\_\_\_\_\_  
Carlton Sprague

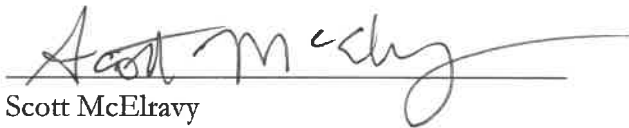
  
\_\_\_\_\_  
Scott McElravy

A TRUE COPY:

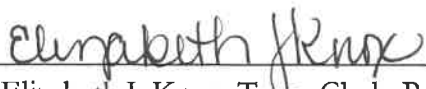
ATTESTED BY:  DATE: December 14, 2020  
Elizabeth J. Knox, Town Clerk, Paris, Maine